

MITECH LEEB HARDNESS TESTER MH310

User's Manual

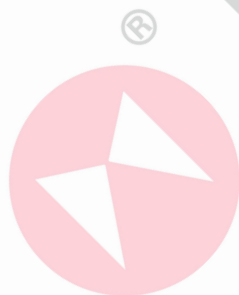

MITECH CO., LTD.
www.ponpe.com

CONTENTS

| | |
|--|----|
| 1 Overview | 3 |
| 1.1 Advantages | 3 |
| 1.2 Main Application & Testing Range | 3 |
| 1.2.1 Main Application | 3 |
| 1.2.2 Testing Range | 3 |
| 1.3 Technical Specifications | 4 |
| 1.4 Configuration | 4 |
| 1.5 Working Conditions | 5 |
| 1.6 Safety Instructions | 5 |
| 2 Structure Feature & Testing Principle | 5 |
| 2.1 Structure Feature | 5 |
| 2.1.1 The Hardness Tester Appearance | 5 |
| 2.1.2 Parts of the Main body | 6 |
| 2.1.3 D Type Impact Device | 7 |
| 2.1.4 Different Types of Impact Device | 7 |
| 2.2 Main Screen | 7 |
| 2.3 Keypad Definitions | 8 |
| 2.4 Leeb Hardness Testing Principle | 9 |
| 3 Preparation | 9 |
| 3.1 Instrument Preparation and Inspection | 9 |
| 3.2 Impact Device Selection | 9 |
| 3.3 Preparation of the Sample Surface | 9 |
| 4 Testing Program | 10 |
| 4.1 Start-Up | 10 |
| 4.3 Localization | 10 |
| 4.4 Testing | 10 |
| 4.5 Read Measured Value | 11 |
| 4.6 Notification | 11 |
| 5 Operation Detail | 11 |
| 5.1 Power On/Off | 11 |
| 5.2 Material Setting | 12 |
| 5.3 Hardness/Strength testing | 12 |
| 5.4 Impact Direction Setting | 12 |
| 5.5 Average Times Setting | 12 |
| 5.6 Data logging | 12 |
| 5.6.1 Viewing stored file/Group | 13 |
| 5.6.2 Deleting selected file/Group | 13 |
| 5.7 Print Function | 13 |
| 5.7.2 Print the stored data | 13 |
| 5.8 Date and Time Set | 14 |
| 5.9 System Reset | 14 |
| 5.10 EL Backlight | 14 |
| 5.11 Auto Power Off | 14 |
| 5.12 Paper Installation | 14 |
| 5.13 Battery Charge | 14 |
| 5.14 Battery Replacement | 15 |
| 5.15 Connecting to a Computer | 15 |
| 5.16 Error Code Reference | 15 |
| 6 Maintenance & Servicing | 15 |
| 6.1 Impact Device Maintenance | 15 |
| 6.2 Instrument Maintenance Program | 15 |
| 6.3 Fault Analysis & Evacuation | 16 |
| 6.4 Notice of Transport and Storage Conditions | 16 |
| APPENDIX | 17 |
| Table 1 | 17 |
| Table 2 | 18 |

| | |
|-------------------------|----|
| Table 3..... | 19 |
| Table 4..... | 20 |
| User Notes | 21 |



1 Overview

1.1 Advantages

- Wide measuring range. Based on the principle of Leeb hardness testing theory. It can measure the Leeb hardness of all metallic materials.
- Large screen LCD, showing all functions and parameters. With EL background light.
- Seven impact devices are available for special application. Automatically identify the type of impact devices.
- Test at any angle, even upside down.
- Direct display of hardness scales HRB, HRC, HRA, HV, HB, HS, HL.
- Large memory could store 100 groups (Relative to average times 32 ~ 1) information including single measured value, mean value, impact direction, impact times, material and hardness scale etc.
- Battery information showing the rest capacity of the battery and the charge status.
- User calibration function.
- Software to connect to PC via USB port.
- Thermal printer integrated, convenient for in field printing.
- NI-MH rechargeable battery as the power source. Charge circuit integrated inside the instrument. Continuous working period of no less than 150 hours (EL off and no printing).
- Auto power off to save energy.
- Outline dimensions: 212mm×80mm×32mm

1.2 Main Application & Testing Range

1.2.1 Main Application

- Die cavity of molds
- Bearings and other parts
- Failure analysis of pressure vessel, steam generator and other equipment
- Heavy work piece
- The installed machinery and permanently assembled parts
- Testing surface of a small hollow space
- Material identification in the warehouse of metallic materials
- Rapid testing in large range and multi-measuring areas for large-scale work piece

1.2.2 Testing Range

Testing range refer to Table 1 and Table 2 in the Appendix.

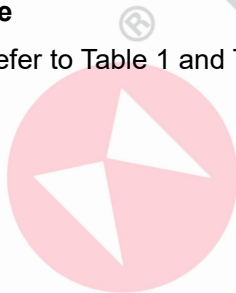

1.3 Technical Specifications

- Error and repeatability of displayed value see Table1-1 below.

Table 1-1

| No. | Type of impact device | Hardness value of Leeb standard hardness block | Error of displayed value | Repeatability |
|-----|-----------------------|--|--------------------------|-----------------|
| 1 | D | 760±30HLD 530±40HLD | ±6 HLD ±10 HLD | 6 HLD 10 HLD |
| 2 | DC | 760±30HLDC 530±40HLDC | ±6 HLDC ±10 HLDC | 6 HLD 10 HLD |
| 3 | DL | 878±30HLDL 736±40HLDL | ±12 HLDL | 12 HLDL |
| 4 | D+15 | 766±30HLD+15 544±40HLD+15 | ±12 HLD+15 | 12 HLD+15 |
| 5 | G | 590±40HLG 500±40HLG | ±12 HLG | 12 HLG |
| 6 | E | 725±30HLE 508±40HLE | ±12 HLE | 12 HLE |
| 7 | C | 822±30HLC 590±40HLC | ±12 HLC | 12 HLC |

- Measuring range: HLD (170~960) HLD
- Measuring direction: 0°~360°
- Hardness Scale: HL、HB、HRB、HRC、HRA、HV、HS
- Display: segment LCD
- Data memory: 100 groups max. (relative to impact times 32~1)
- Printing paper: width is (57.5±0.5) mm, diameter is 30mm.
- Battery pack: 6V NI-MH
- Battery charger: 9V/500mA
- Continuous working period: about 150 hours (With backlight off, no printing)
- Communication interface: USB1.1

1.4 Configuration

Table 1-2

| | No. | Item | Quantity | Remarks |
|------------------------|-----|--|----------|---|
| Standard Configuration | 1 | Main unit | 1 | |
| | 2 | D type impact device | 1 | With cable |
| | 3 | Standard test block | 1 | |
| | 4 | Cleaning brush (I) | 1 | |
| | 5 | Small support ring | 1 | |
| | 6 | Battery Charger | 1 | 9V 500mA |
| | 7 | Paper for printing | 1 | |
| | 8 | Manual | 1 | |
| | 9 | Instrument package case | 1 | |
| Optional Configuration | 11 | Cleaning brush (II) | 1 | For use with G type impact device |
| | 12 | Other type of impact devices and support rings | | Refer to Table 3 and Table 4 in the appendix. |
| | 13 | DataPro software | 1 | |
| | 14 | Communication cable | 1 | |
| | 15 | | | |
| | 16 | | | |

1.5 Working Conditions

Working temperature: $-10^{\circ}\text{C} \sim +50^{\circ}\text{C}$;

Storage temperature: $-30^{\circ}\text{C} \sim +60^{\circ}\text{C}$;

Relative humidity: $\leq 90\%$;

The surrounding environment should avoid of vibration, strong magnetic field, corrosive medium and heavy dust.

1.6 Safety Instructions

- The instrument can only work with the specially designed battery pack and power adapter (charger) supplied by Mitech Co. LTD. Working with others may result in damage of the instrument, battery leakage, fire or even explosion.
- Do not cast the battery pack into fire and do not short circuit, disassemble or heat the battery pack, otherwise battery leakage, fire or even explosion may occur.
- Do not open the cover of the paper compartment or come into contact with the heating head of the printer by hand or any part of your body to avoid burns due to high temperature when the printer is printing.

2 Structure Feature & Testing Principle

2.1 Structure Feature

2.1.1 The Hardness Tester Appearance

1. Main unit

2. Impact device

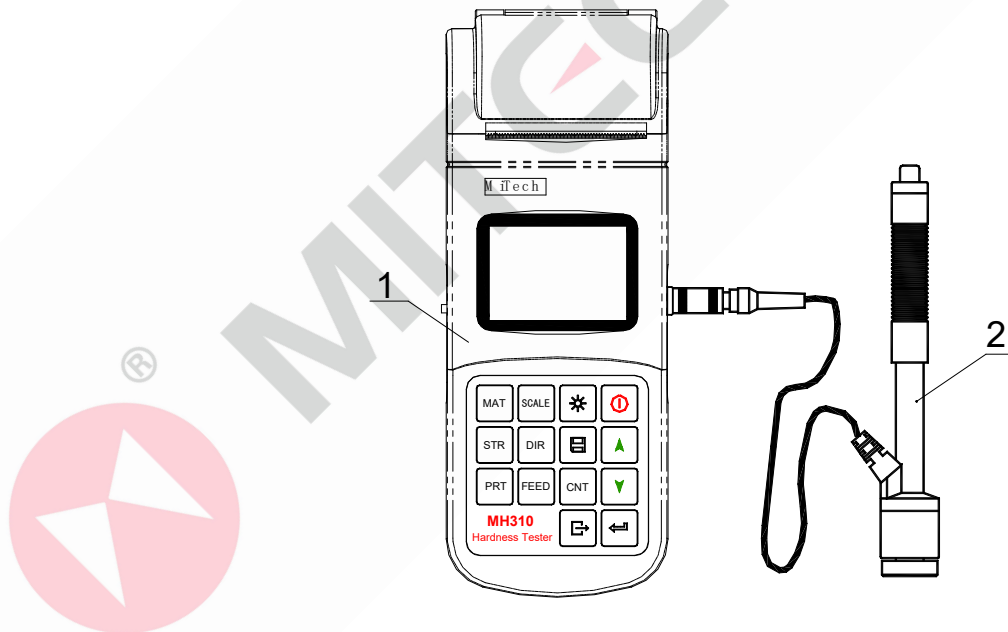

2.1.2 Parts of the Main body

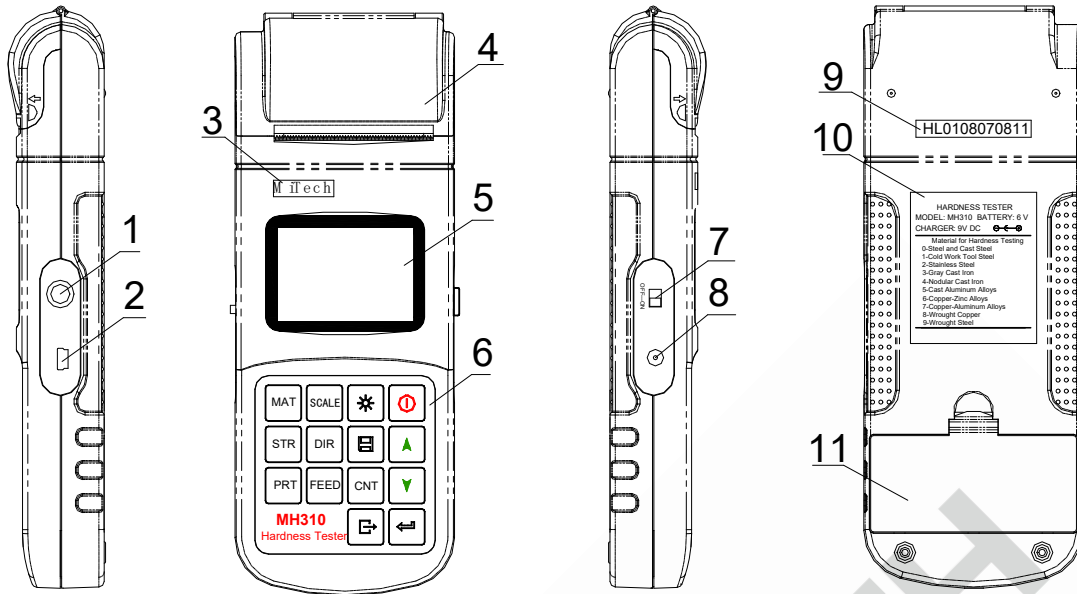

1 Socket of impact device 2 Socket of USB 3 LOGO 4 Paper compartment cover 5 LCD display 6 Keypad 7 Battery switch 8 Power jack 9 Serial Number 10 Product label 11 Battery compartment cover



2.1.3 D Type Impact Device

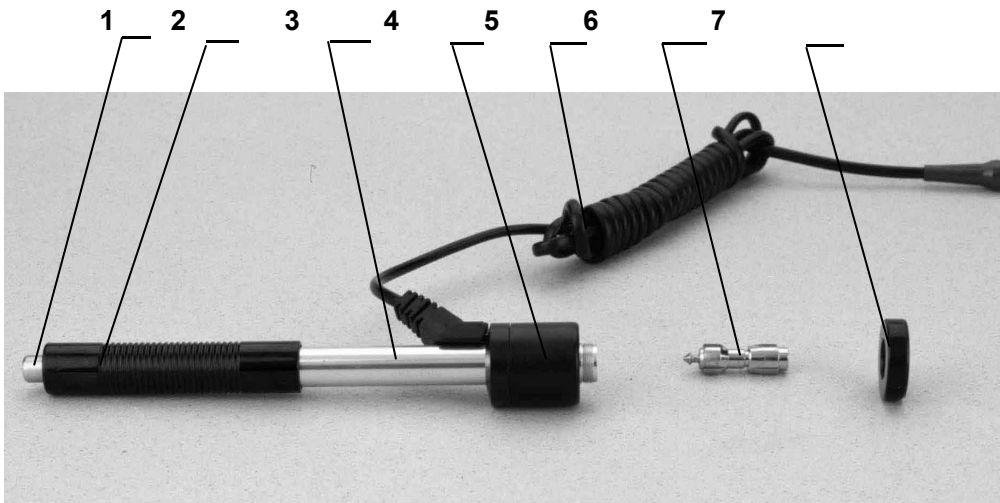

- 1 Release button 2 Loading tube 3 Guide tube 4 Coil unit
 5 Connection cable 6 Impact body 7 Support ring

2.1.4 Different Types of Impact Device

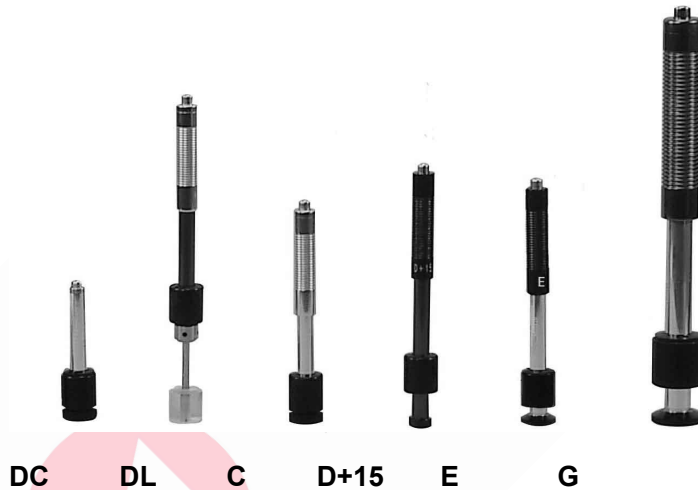

2.2 Main Screen

Below is the main display screen:

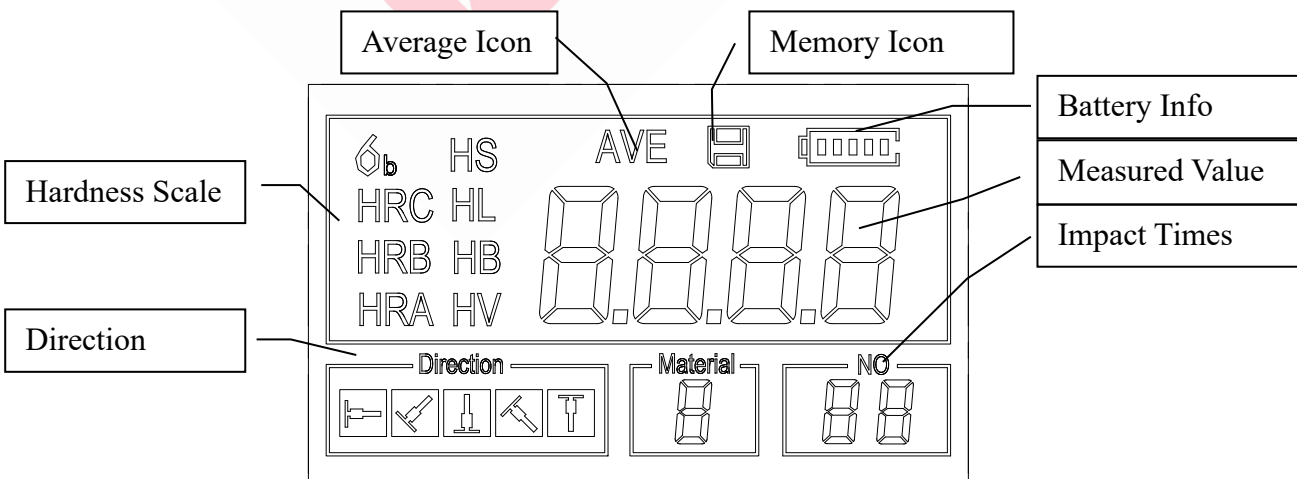





























Instruction of the Main Display Screen:

- **Material:** The present presetting material.
- **Impact direction:** The present impact direction.
- **Hardness scale:** Hardness scale of the present measured value.
- **Battery information:** Showing the rest capacity of the battery and the charging status.
- **Measured value:** Display present single time measured value (without showing average icon), or display the present mean value (with average icon prompting). “-HI-” means over conversion value or measure range. “-LO-” means lower than conversion value or measure range.
- **Impact times:** Times that have been impacted.
- **Average Icon:** It will appear when showing the mean value of the measured values after reaching the presetting impact times.
- **Memory Icon:** It appears when operating the instrument memory.

2.3 Keypad Definitions

Table 2-1

| | | | | | |
|---|------------------------------|---|--------------------------|--|----------------------------|
|  | Turn on/off the EL backlight |  | Data Save or Data Delete |  | Turn the instrument on/off |
|  | Material Selection |  | Hardness/Strength switch |  | Plus or Up |
|  | Hardness Scale Selection |  | Direction change |  | Minus or Down |
|  | Manual Feed Paper |  | Impact Times set | | |
|  | Print data |  | Cancel or Exit |  | Data logging or Enter |

- Press  key to store present group of measured value into memory. This operation is only valid after displaying the mean value.
- Press key  and  could display single measured value.
- Press  key could switch on of off the background light of LCD.
- Press  key to set the impact direction.
- Press  key to change the impact times in one group. The impact times item will flash when first pressing the  key, and then the impact times value will plus or minus when pressing the  or  key. Press  key finally to exit from changing the impact times process.
- Press  key to change the hardness scale.
- Press  key to change the material. Presetting hardness scale recovers to HL automatically after material presetting changed.
- Press  key to switch between hardness test and strength test. Only D and DC type of impact device has the function of strength testing. So hardness testing is the only selection if the impact device is not D or DC type.
- Press  key to print out the measured values after measurement.
- Press  key to manually feed the paper.

2.4 Leeb Hardness Testing Principle

The basic principle is to use an impact body of certain weight impacts against the testing surface under certain test force, then measure the impacting velocity and the rebounding velocity of the impact body respectively when the spherically test tip is located 1mm above the testing surface.

The calculation formula is as follows:



$$HL=1000 \times VB / VA$$

Where, HL—— Leeb hardness value
 VB—— Rebounding velocity of the impact body
 VA—— Impacting velocity of the impact body



3 Preparation

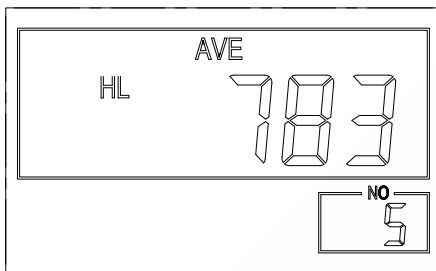

3.1 Instrument Preparation and Inspection

Verification of the instrument is by using standard test block. The error and repeatability of displayed value should be within the regulation of Appendix table 2. The instrument and impact device must be calibrated using a standard hardness block before use as the first time, or having not been used for a long time, or having reset the instrument system.

Press  key, meanwhile pressing down the  key to power on the system. Then the user calibration screen shows as left below.



Test for 5 points on the standard hardness block. It would display the average measured value after measuring 5 times. Press   key to change to its nominal value.

Press  key to confirm the calibration finally. Or press the  key to cancel the calibration.

Range of adjustment: ±30HL.

3.2 Impact Device Selection

Refer to Appendix Table 1 and Table 3 for selection of impact device.

3.3 Preparation of the Sample Surface

Preparation for sample surface should conform to the relative requirement in Appendix Table 3.

- In the preparation processing for sample surface, the hardness effect of being heated or cold processing on the surface of sample should be avoided.
- Too big roughness of the being measured surface could cause error. So, the surface of the sample to be measured must appear metallic luster, smoothing and polish, without oil stain.
- Support of test sample. Support is no necessary for heavy sample. Medium-weight parts must be set on the smoothing and stable plane. The sample must set absolutely equability and without any wobble.
- Curved surface: The best testing surface of sample is flat. When the curvature radius R of the surface to be tested is smaller than 30mm (D, DC, D+15,C, E and DL type of impact device) and smaller than 50mm (G type of impact device), the small support ring or the shaped support rings should be chosen.
- The sample should have enough thickness, minimum thickness of sample should conform to Table 3.
- For the sample with hardened layer on surface, the depth of hardened layer should conform to Table 3.

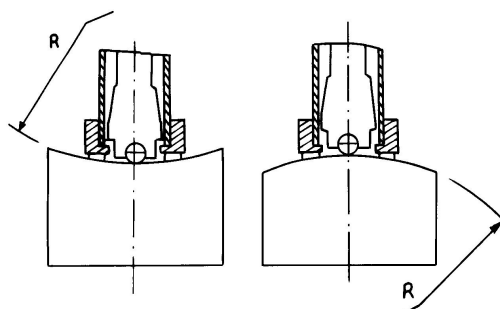

- Coupling. Light-weight sample must be firmly coupled with a heavy base plate. Both coupled surface must be flat and smooth, and there is no redundant coupling agent existing. The impact direction must be vertical to the coupled surface. When the sample is a big plate, long rod or bending piece, it can be deformed and become unstable, even though its weight and thickness is big enough, and accordingly, the test value may not be accurate. So the sample should be reinforced or supported at its back.
- Magnetism of the sample itself should be avoided.

4 Testing Program

Note : Use a calibrated hardness tester, test the standard test block downward vertically for 5 times, the arithmetical average value compare with the value of standard test block. If this value exceeds the standard value, could use the function of user calibration to adjust.

4.1 Start-Up

- Insert the plug of the impact device into the socket of impact device on the instrument.
 - Press the  key, now power is on. The instrument is in working mode.
- Pushing the loading-tube downwards until contact is felt. Then allow it to slowly return to the starting position or using other method locking the impact body.



4.3 Localization

Press the impact device supporting ring firmly on the surface of the sample, the impact direction should be vertical to the testing surface.

4.4 Testing

- Press the release button on the upside of the impact device to test. The sample and the impact device as well as the operator are all required to be stable now. The action direction should pass the axis of the impact device.
- Each measure area of the sample usually need 3 to 5 times of testing operation. The result data dispersion should not more than mean value \pm 15HL.
- The distance between any two impact points or from the center of any impact point to the edge of testing sample should conform to the regulation of Table 4-1.
- If want accurate conversion from the Leeb hardness value to other hardness value, contrastive test is needed to get conversion relations for the special material. Use inspection qualified Leeb hardness tester and corresponding hardness tester to test at the same sample respectively. For each hardness value, each measure homogeneously 5 points of Leeb hardness value in the surrounding of more than three indentations which need conversion hardness, using Leeb hardness arithmetic average value and corresponding hardness average value as correlative value respectively, make individual hardness contrastive curve. Contrastive curve at least should include three group of correlative data.

Table 4-1

| Type of Impact Device | Distance of center of the two indentations | Distance of center of the indentation to sample edge |
|-----------------------|--|--|
| | Not less than (mm) | Not less than (mm) |
| D、DC | 3 | 5 |
| DL | 3 | 5 |
| D+15 | 3 | 5 |
| G | 4 | 8 |
| E | 3 | 5 |
| C | 2 | 4 |

4.5 Read Measured Value

After each impact operation, the LCD will display the current measured value, impact times plus one, the buzzer would alert a long howl if the measured value is not within the valid range. When reaching the presetting impact times, the buzzer will alert a long howl. After 2 seconds, the buzzer will alert a short howl, and display the mean measured value.

NOTE:HL values tested by different impact devices are different, eg.780HLD≠780HLC

4.6 Notification

- Replacing the impact device must be done during Power off. Otherwise the main body could not identify the type of the impact device, and it may damage the circuit board of the main body.
- You could not save the current test value if the impact time is less than the presetting times value.
- Only type D and type DC of impact device have the function of strength test option. You can not change the setting to strength testing when using other types of impact device. The setting would be set to hardness testing automatically after replacing the impact device whether the setting is hardness testing or not before.
- Not all materials could convert to all hardness scale value. The hardness scale is reset to HL automatically after changing the material. So select material firstly before changing the hardness scale.

5 Operation Detail

5.1 Power On/Off

Press  to power on the instrument. Be sure to plug in the impact device before powering on. The system would automatically detect the type of the impact device during power up, and would display this information on the screen. Users should pay attention to the probe type displayed on the screen. After pausing for several second, the screen will exit and enter the main display screen as following:

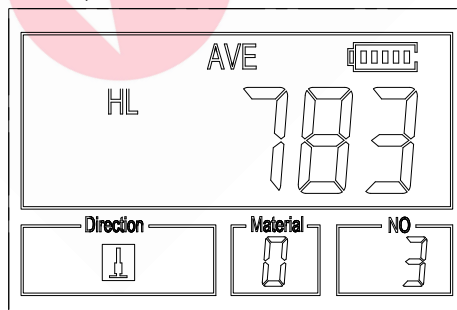

The instrument can be turned off by pressing the  key while it is working. The tool has a special memory that retains all of its settings even when the power is off.

Note: If the instrument is in power off condition, it will turns on automatically after the charge power is connected.

5.2 Material Setting

Press key to change the material to the one you want to preset. Hardness scale recovers to HL automatically after material presetting changed. Please select material firstly, then select hardness scale.

In hardness testing, you can select the material among the following materials: Steel and Cast Steel、Cold Work Tool Steel、Stainless Steel、Gray Cast Iron、Nodular Cast Iron、Cast Aluminum Alloys、Copper-Zinc Alloys、Copper-Aluminum Alloys、Wrought Copper and Wrought Steel. The relationship between the material number displayed on the instrument screen and the material is as follows:

Table 5-1

| Material No. | Material | Material No. | Material |
|--------------|----------------------|--------------|-------------------------|
| 0 | Steel and cast steel | 5 | Cast aluminum alloys |
| 1 | Cold work tool steel | 6 | Copper-Zinc alloys |
| 2 | Stainless steel | 7 | Copper –Aluminum alloys |
| 3 | Gray cast iron | 8 | Wrought copper |
| 4 | Nodular cast iron | 9 | Wrought steel |

In strength testing, the following materials are selectable: Mild Steel、High-Carbon Steel、Cr Steel、Cr-V Steel、Cr-Ni Steel、Cr-Mo Steel、Cr-Ni-Mo Steel、Cr-Mn-Si Steel、Super Strength Steel and Stainless Steel. The relationship between the material number displayed on the instrument screen and the material is as follows:

Table 5-2

| Material No | Material | Material No | Material |
|-------------|-------------------|-------------|----------------------|
| 0 | Mild steel | 5 | Cr-Mo steel |
| 1 | High carbon steel | 6 | Cr-Ni-Mo steel |
| 2 | Cr steel | 7 | Cr-Mn-Si steel |
| 3 | Cr-V steel | 8 | Super strength steel |
| 4 | Cr-Ni steel | 9 | Stainless steel |

NOTE”

- 1.The hardness scale will return to HL after changing the material setting.
- 2.Please choose the material before choosing hardness scale.

5.3 Hardness/Strength testing

Press key to switch between hardness testing and strength testing (6b) .

Note: Only D and DC type of impact device has the function of strength testing. So hardness testing is the only selection if the impact device is not D or DC type.

In hardness testing, Press key to change the hardness scale. The supported hardness scale includes: HL, HV, HB, HRC, HS, HRB and HRA.

Note:

- Here only displays the valid hardness scale for the present selected impact device and material. It would not display the hardness scale which is not valid.
- Please select material firstly, then select hardness scale.
- Presetting hardness scale recovers to HL automatically after presetting material is changed.

5.4 Impact Direction Setting

Press the key to move to the impact direction that you will preset.

5.5 Average Times Setting

You could modify average times within the range of 1 to 32 as following:

- 1) Press key in testing state. The impact times item will begin to flash.
- 2) Press or key to set the average times to the number you want.
- 3) Press key finally to exit from the operation.







5.6 Data logging

At most one hundred files (F00-F99, one group as one file) can be stored inside the gauge. By simply

pressing the  key after a new measurement finishes-the screen showing the “AVE” icon, the measured hardness/strength group values will be saved to memory. The new saved file is appended as the last file of the memory. This function provides the user with the ability to view/delete a file/group previously saved in memory.









5.6.1 Viewing stored file/Group

To view the memory data, follow the steps:

- 1) Press the  key to activate the data logging function. The memory icon will appear. It will display the current file name, the test parameter of the group data and the mean value of the group. If there is no data in the memory, it will display: <E04>, which means no memory data, and then return back.
- 2) Use the  key and the  key to select the desired file to view.
- 3) Press the  key to see details of that group data.
- 4) Use the  key and the  key to view each single measured data in that group while viewing details.
- 5) Press the  key to return to previous screen at any time during data logging.

5.6.2 Deleting selected file/Group

The user may require deleting a file from the instrument memory. The procedure is outlined in the following steps.







- 1) Press the  key to activate the data logging function. The memory icon will appear. It will display the current file name, the test parameter of the group data and the mean value of the group. If there is no data in the memory, it will display: <E04>, which means no memory data, and then return back.
- 2) Use the  key and the  key to scroll to the file that will be deleted. Press the  key on the desired file. It will automatically delete the file, and display “-DEL”. After you delete, the data number will list again which needs about 30 seconds, don't turn off the machine to avoid data error.
- 3) Press the  key to exit the data logging function or press  to selected data group for details
- 4) Use the  key and the  key for single test in data groups.
- 5) Press  to return step 3 and return to measurement mode.

5.7 Print Function



At the end of the inspection process, or end of the day, the user may require the readings be printed. You can print out the measurement result immediately after each testing process, by easily pressing the  key.

5.7.2 Print the stored data

If you want to print the data stored in the instrument memory, then following is the steps:

1. Power on the machine
2. Press the  key to activate the data logging function. The memory icon will appear.
3. Use the  key and the  key to select the desired file.
4. Press the  key to print the selected file. This operation will print out all the data in current file.
5. Press the  key to exit the data logging functions and return to measurement mode.
6. Press the  key to stop printing after current printing during the printing period.

5.7.3 Manually feeding paper





When the printer is powered on and ready for printing, press  key then the instrument will start manual paper feeding. Press and keep holding the  key to start paper feeding, while releasing the key to stop paper feeding.

Note:

- **Printing function is unavailable while charging.**
- **Printing can be stopped by pressing the  key.**
- **Do not open the cover of the paper compartment during printing. Otherwise the instrument may not print normally.**
- **Over high ambient humidity (above 85% of relative humidity) or over low ambient humidity (below 20% of relative humidity) may reduce the print quality.**

- **Printing with paper that has been stored for over long period of time or of poor quality may reduce the print quality or even damage the printer.**

5.8 Date and Time Set

Press down the  key while powering on the instrument to set the instrument date and time. The year item shown as "XXXX" will firstly prompt out. Use the  key and the  key to change to current year. Confirm the change by pressing  and step to next item. In the following, the Month, Date, Hour and Minute item will prompt out in turn. You can cancel all the changes by pressing  and exit from the date and time setting at any time during the operation.

5.9 System Reset

Press down the  key while powering on the instrument will restore factory defaults. The only time this might possibly helpful is if the parameter in the instrument was somehow corrupted.

5.10 EL Backlight

With the EL background light, it is convenient to work in the dark condition. Press key  to switch on or switch off the background light at any moment as you need after power on. Since the EL light will consume much power, turn on it only when necessary.

5.11 Auto Power Off

The instrument features an auto power off function designed to conserve battery life. If the tool is idle (neither measuring nor any key operation) for 5 minutes, it will turn itself off. Before powering off, the LCD display of the instrument will continue flashing for 20 seconds. Except key , press any key could stop the twinkle of LCD screen and stop the operation of power off at the moment.

While the voltage of the battery is too low, the display will show <E00>, then power off automatically.

When the instrument is being charged, the Auto Power Off will not function.

5.12 Paper Installation

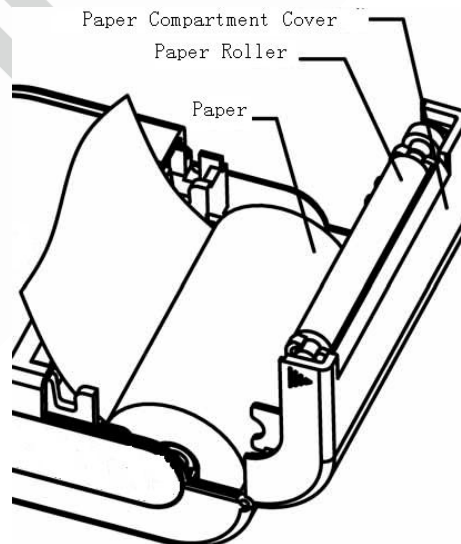

- Hold Both ends of the paper compartment with fingers and open the compartment cover with moderate strength.
- According to the illustration, put the paper into the paper compartment with attention to the paper direction. If the paper is misplaced, the instrument will fail to print.
- Pull a trip of paper out of the compartment.
- Make sure that the paper is well in place and close the paper compartment cover.



5.13 Battery Charge

The instrument uses a NI-MH battery pack as its power source. When the battery pack almost runs out, the battery symbol on the display will glint . It needs charging as soon as possible. Try to drain your battery pack as fully as possible before it is charged for longest battery service.

- The battery switch should be at 'ON' condition before charging.
- Plug the power adapter into the mains supply power socket and then plug the charger connector into the power jack of the instrument. If the instrument is in power off condition, it will turns on automatically after the charger plug is inserted into the power jack. The battery symbol will

alternately shows between  and  when charging. The more of the dark part indicates the more close to full capacity.

- When the battery is fully charged, the battery symbol on the display will glint .
- Please use the configured AC-DC adapter to charge the battery pack.

5.14 Battery Replacement

When the battery pack fails to be charged, the user should replace the batteries following the program below:

- Power down the instrument.
- Take off the battery compartment cover and take out the battery pack.
- Insert the connection plug of the new battery pack into the socket on the circuit board.
- Reset the battery cover.
- Turn on the instrument to check.

Warning: Please pay much attention to the polarity of the battery during battery replacement.

5.15 Connecting to a Computer

Insert one connection plug of the transmission cable into the USB socket on the right side of main body, and insert the another plug into the USB port on the back of computer box. Refer to the manual of the DataPro software for detailed information.

5.16 Error Code Reference

| Error Code | Explanation | Error Code | Explanation |
|------------|--------------------------|------------|-----------------------|
| E00 | Battery exhausted | E05 | Can not print |
| E01 | Value out of range | E06 | Battery Charging |
| E02 | Measurement not finished | E07 | No paper for printing |
| E03 | Data already saved | E08 | Over Temperature |
| E04 | No memory data | E09 | |

6 Maintenance & Servicing

6.1 Impact Device Maintenance

- After the impact device has been used for 1000--2000 times, please use the nylon brush provided to clean the guide tube and impact body. When cleaning the guide tube, unscrew the support ring first, then take out the impact body, spiral the nylon brush in counter-clock direction into the bottom of guide tube and take it out for 5 times, and then install the impact body and support ring again.
- Release the impact body after use.
- Any lubricant is absolutely prohibited inside the impact device.

6.2 Instrument Maintenance Program

- When using standard Rockwell hardness block to testing, if all the error is bigger than 2 HRC, it may be the invalidation of impacted ball top caused by abrasion. Changing the spherical test tip or impact object should be considered.
- When the hardness tester appears some other abnormal phenomena, please do not dismantle or adjust any fixedly assembled parts. Fill in and present the warranty card to us. The warranty service can be carried on.

6.3 Fault Analysis & Evacuation

| Fault Appearance | Fault Analysis | Handling method |
|-------------------|-----------------------------|-------------------------------------|
| Charge failure | Battery failure | Replace the battery with a new pack |
| | The battery is switched off | Switch on the battery |
| No measured value | Impact device cable failure | Replace the cable |
| Failure power on | Battery exhaustion | Charge the battery |
| | The battery is switched off | Switch on the battery |

6.4 Notice of Transport and Storage Conditions

- Keep it away from vibration, strong magnetic field, corrosive medium, dampness and dust. Storage in ordinary temperature.
- With original packing, transport is allowed on the third grade highway.

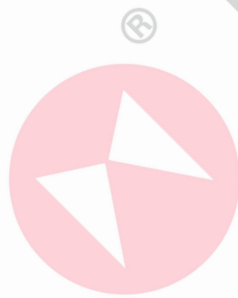

MITTECH

APPENDIX
Table 1

| Material | Method | Impact device | | | | | |
|------------------------------------|--------|---------------|-----------|------------|-----------|------------|-----------|
| | | D/DC | D+15 | C | G | E | DL |
| Steel and cast steel | HRC | 20~68.5 | 19.3~67.9 | 20.0~69.5 | | 22.4~70.7 | 20.6~68.2 |
| | HRB | 38.4~99.6 | | | 47.7~99.9 | | 37.0~99.9 |
| | HRA | 59.1~85.8 | | | | 61.7~88.0 | |
| | HB | 127~651 | 80~638 | 80~683 | 90~646 | 83~663 | 81~646 |
| | HV | 83~976 | 80~937 | 80~996 | | 84~1042 | 80~950 |
| | HS | 32.2~99.5 | 33.3~99.3 | 31.8~102.1 | | 35.8~102.6 | 30.6~96.8 |
| Cold work tool steel | HRC | 20.4~67.1 | 19.8~68.2 | 20.7~68.2 | | 22.6~70.2 | |
| | HV | 80~898 | 80~935 | 100~941 | | 82~1009 | |
| Stainless steel | HRB | 46.5~101.7 | | | | | |
| | HB | 85~655 | | | | | |
| | HV | 85~802 | | | | | |
| Grey cast iron | HRC | | | | | | |
| | HB | 93~334 | | | 92~326 | | |
| | HV | | | | | | |
| Nodular cast iron | HRC | | | | | | |
| | HB | 131~387 | | | 127~364 | | |
| | HV | | | | | | |
| Cast aluminum alloys | HB | 19~164 | | 23~210 | 32~168 | | |
| | HRB | 23.8~84.6 | | 22.7~85.0 | 23.8~85.5 | | |
| BRASS(copper-zinc alloys) | HB | 40~173 | | | | | |
| | HRB | 13.5~95.3 | | | | | |
| BRONZE(copper-aluminum/tin alloys) | HB | 60~290 | | | | | |
| Wrought copper alloys | HB | 45~315 | | | | | |

Table 2

| No. | Material | HLD | Strength σ_b (MPa) |
|-----|----------------------|---------|---------------------------|
| 1 | Mild steel | 350~522 | 374~780 |
| 2 | High-Carbon steel | 500~710 | 737~1670 |
| 3 | Cr steel | 500~730 | 707~1829 |
| 4 | Cr-V steel | 500~750 | 704~1980 |
| 5 | Cr-Ni steel | 500~750 | 763~2007 |
| 6 | Cr-Mo steel | 500~738 | 721~1875 |
| 7 | Cr-Ni-Mo steel | 540~738 | 844~1933 |
| 8 | Cr-Mn-Si steel | 500~750 | 755~1993 |
| 9 | Super strength steel | 630~800 | 1180~2652 |
| 10 | Stainless steel | 500~710 | 703~1676 |



Table 3

| Type of impact device | | DC(D)/DL | D+15 | C | G | E |
|--|----------------------|---|--|--|---|--------------------------------------|
| Impacting energy | | 11mJ | 11mJ | 2.7mJ | 90mJ | 11mJ |
| Mass of impact body | | 5.5g/7.2g | 7.8g | 3.0g | 20.0g | 5.5g |
| Test tip hardness: | | 1600HV | 1600HV | 1600HV | 1600HV | 5000HV |
| Dia. Test tip: | | 3mm | 3mm | 3mm | 5mm | 3mm |
| Material of test tip: | | Tungsten carbide | Tungsten carbide | Tungsten carbide | Tungsten carbide | synthetic diamond |
| Impact device diameter: | | 20mm | 20mm | 20mm | 30mm | 20mm |
| Impact device length: | | 86(147)/ | 162mm | 141mm | 254mm | 155mm |
| Impact device weight: | | 75mm 50g | 80g | 75g | 250g | 80g |
| Max. hardness of sample | | 940HV | 940HV | 1000HV | 650HB | 1200HV |
| Mean roughness value of sample surface Ra: | | 1.6µm | 1.6µm | 0.4µm | 6.3µm | 1.6µm |
| Min. weight of sample: | | >5kg | >5kg | >1.5kg | >15kg | >5kg |
| Measure directly | | 2~5kg | 2~5kg | 0.5~1.5kg | 5~15kg | 2~5kg |
| Need support firmly | | 0.05~2kg | 0.05~2kg | 0.02~0.5kg | 0.5~5kg | 0.05~2kg |
| Need coupling tightly | | | | | | |
| Min. thickness of sample | | | | | | |
| Coupling tightly | | 5mm | 5mm | 1mm | 10mm | 5mm |
| Min. layer thickness for surface hardening | | ≥0.8mm | ≥0.8mm | ≥0.2mm | ≥1.2mm | ≥0.8mm |
| Size of tip indentation | | | | | | |
| Hardness 300HV | Indentation diameter | 0.54mm | 0.54mm | 0.38mm | 1.03mm | 0.54mm |
| | Depth of indentation | 24µm | 24µm | 12µm | 53µm | 24µm |
| Hardness 600HV | Indentation diameter | 0.54mm | 0.54mm | 0.32mm | 0.90mm | 0.54mm |
| | Depth of indentation | 17µm | 17µm | 8µm | 41µm | 17µm |
| Hardness 800HV | Indentation diameter | 0.35mm | 0.35mm | 0.35mm | -- | 0.35mm |
| | Depth of indentation | 10µm | 10µm | 7µm | -- | 10µm |
| Available type of impact device | | DC: Test hole or hollow cylindrical; DL: Test slender narrow groove or hole | D+15: Test groove or reentrant surface | C: Test small, light, thin parts and surface of hardened layer | G: Test large, thick, heavy and rough surface steel | E: Test super high hardness material |

Table 4

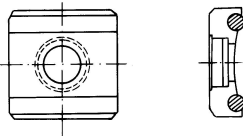
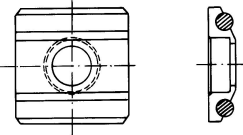
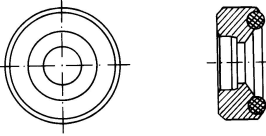
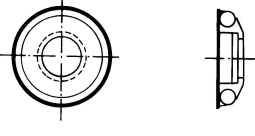
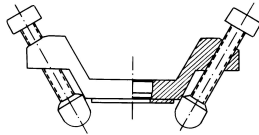
| No. | Type | Sketch of non-conventional Supporting ring | Remarks |
|-----|-----------|---|--|
| 1 | Z10-15 |  | For testing cylindrical outside surface R10~R15 |
| 2 | Z14.5-30 | | For testing cylindrical outside surface R14.5~R30 |
| 3 | Z25-50 | | For testing cylindrical outside surface R25~R50 |
| 4 | HZ11-13 |  | For testing cylindrical inside surface R11~R13 |
| 5 | HZ12.5-17 | | For testing cylindrical inside surface R12.5~R17 |
| 6 | HZ16.5-30 | | For testing cylindrical inside surface R16.5~R30 |
| 7 | K10-15 |  | For testing spherical outside surface SR10~SR15 |
| 8 | K14.5-30 | | For testing spherical outside surface SR14.5~SR30 |
| 9 | HK11-13 |  | For testing spherical inside surface SR11~SR13 |
| 10 | HK12.5-17 | | For testing spherical inside surface SR12.5~SR17 |
| 11 | HK16.5-30 | | For testing spherical inside surface SR16.5~SR30 |
| 12 | UN |  | For testing cylindrical outside surface, radius adjustable R10~∞ |

User Notes

Warranty:

The product is guaranteed for one year since purchased. Log www.mitech-ndt.com or follow our company official public platform to register for maintenance. Please fill the blanks as required, if the product is not registered for maintenance, it will follow the date of manufacturer.

When applying for maintenance, please visit our official website, www.mitech-ndt.com or official accounts, submit “online reporting to repair” sheet.

In accordance with the international relevant regulations, the following are not within the scope of free warranty,

- Damage caused by man-made or improper keeping;
- Self-dismantle or non-special repair shop dismantle;
- Do not follow the requirement of service registration or warranty expired;
- Consumable parts.

Service promise:

- MITECH users have lifelong maintenance service
- Free maintenance, inspection, software upgrade and etc.